

Brushless DC Motor Controller

FEATURES

- Drives Power MOSFETs or Power Darlingtons Directly
- 50V Open Collector High-Side Drivers
- Latched Soft Start
- High-speed Current-Sense Amplifier with Ideal Diode
- Pulse-by-Pulse and Average Current Sensing
- Over-Voltage and Under-Voltage Protection
- Direction Latch for Safe Direction Reversal
- Tachometer
- Trimmed Reference Sources 30mA
- Programmable Cross-Conduction Protection

DESCRIPTION

The UC1625 and UC3625 motor controller ICs integrate most of the functions required for high-performance brushless DC motor control into one package. When coupled with external power MOSFETs or Darlingtons, these ICs perform fixed-frequency PWM motor control in either voltage or current mode while implementing closed loop speed control and braking with smart noise rejection, safe direction reversal, and cross-conduction protection.

Although specified for operation from power supplies between 10V and 18V, the UC1625 can control higher voltage power devices with external level-shifting components. The UC1625 contains fast, high-current push-pull drivers for low-side power devices and 50V open-collector outputs for high-side power devices or level shifting circuitry.

The UC1625 is characterized for operation over the military temperature range of -55°C to $+125^{\circ}\text{C}$, while the UC2625 is characterized from -40°C to $+105^{\circ}\text{C}$ and the UC3625 is characterized from 0°C to 70°C . (NOTE: ESD Protection to 2kV)

BLOCK DIAGRAM

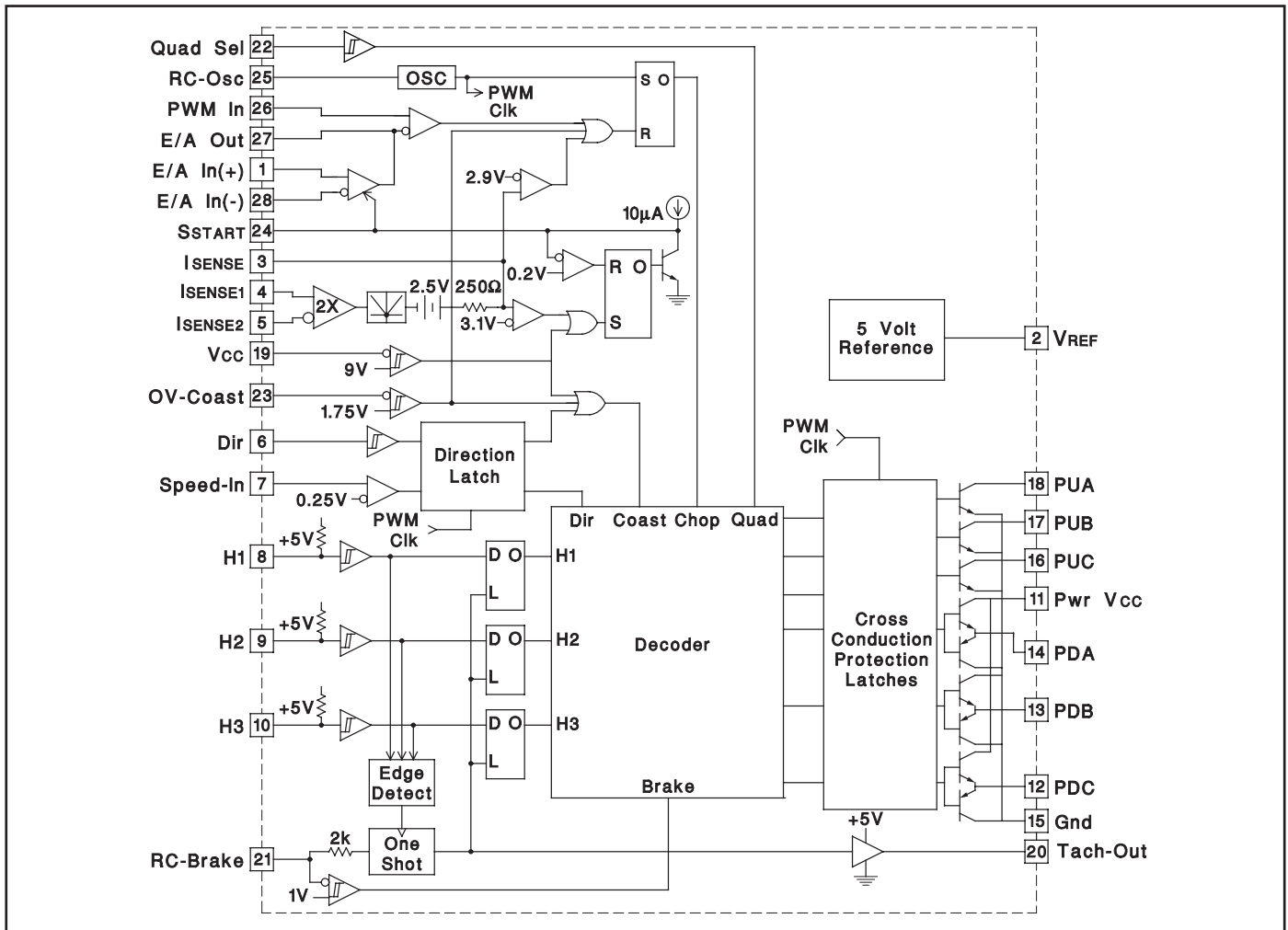

ABSOLUTE MAXIMUM RATINGS

Vcc Supply Voltage	+20V
Pwr Vcc Supply Voltage	+20V
PWM In	-0.3 to 6V
E/A IN(+), E/A IN(-)	-0.3 to 12V
ISENSE1, ISENSE2	-1.3 to 6V
OV-Coast, Dir, Speed-In, SSTART, Quad Sel	-0.3 to 8V
H1, H2, H3	-0.3 to 12V
PU Output Voltage	-0.3 to 50V
PU Output Current	+200 mA continuous
PD Output Current	±200 mA continuous
E/A Output Current	±10 mA
I SENSE Output Current	-10 mA
Tach Out Output Current	±10 mA
VREF Output Current	-50 mA continuous
Operating Temperature Range UC1625	-55°C to 125°C
Operating Temperature Range UC2625	-40°C to 105°C
Operating Temperature Range UC3625	0°C to 70°C

Note 1: Currents are positive into and negative out of the specified terminal.

Note 2: Consult Unitorde Integrated Circuits databook for information regarding thermal specifications and limitations of packages.

CONNECTION DIAGRAM

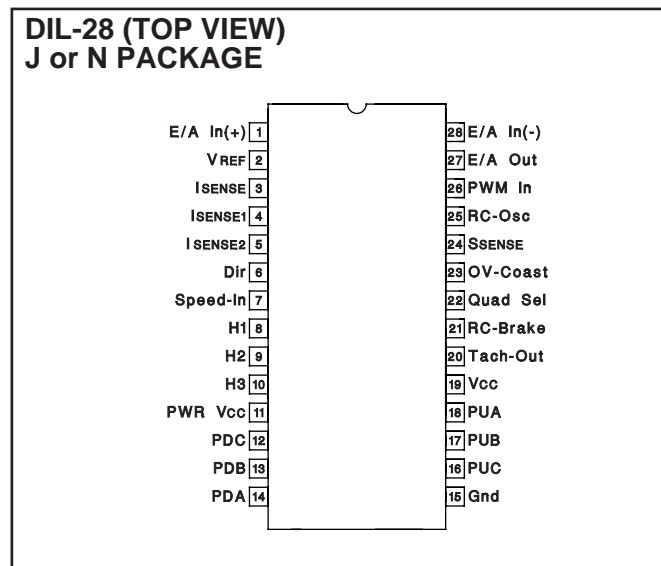

Note 3: This pinout applies to the SOIC (DW), PLCC (Q), and LCC (L) packages (ie. pin 22 has the same function on all packages.)

ELECTRICAL CHARACTERISTICS: Unless otherwise stated, these specifications apply for: TA = 25°C; Pwr VCC = VCC = 12V; ROSC = 20k to VREF; COSC = 2nF; RTACH = 33k; CTACH = 10nF; and all outputs unloaded. TA = TJ.

PARAMETER	TEST CONDITIONS	MIN	TYP	MAX	UNITS
Overall					
Supply current	Over Operating Range		14.5	30.0	mA
Vcc Turn-On Threshold	Over Operating Range	8.65	8.95	9.45	V
Vcc Turn-Off Threshold	Over Operating Range	7.75	8.05	8.55	V
Overvoltage/Coast					
OV-Coast Inhibit Threshold	Over Operating Range	1.65	1.75	1.85	V
OV-Coast Restart Threshold		1.55	1.65	1.75	V
OV-Coast Hysteresis		0.05	0.10	0.15	V
OV-Coast Input Current		-10	-1	0	µA
Logic Inputs					
H1, H2, H3 Low Threshold	Over Operating Range	0.8	1.0	1.2	V
H1, H2, H3 High Threshold	Over Operating Range	1.6	1.9	2.0	V
H1, H2, H3 Input Current	Over Operating Range, to 0V	-400	-250	-120	µA
Quad Sel, Dir Thresholds	Over Operating Range	0.8	1.4	2.0	V
Quad Sel Hysteresis			70		mV
Dir Hysteresis			0.6		V
Quad Sel Input Current		-30	50	150	µA
Dir Input Current		-30	-1	30	µA
PWM Amp/Comparator					
E/A In(+), E/A In(-) Input Current	To 2.5V	-5.0	-0.1	5.0	µA
PWM In Input Current	To 2.5V	0	3	30	µA
Error Amp Input Offset	0V < VCOMMON-MODE < 3V	-10		10	mV
Error Amp Voltage Gain		70	90		dB
E/A Out Range		0.25		3.50	V
SSTART Pull-up Current	To 0V	-16	-10	-5	µA
SSTART Discharge Current	To 2.5V	0.1	0.4	3.0	mA

ELECTRICAL CHARACTERISTICS (cont): Unless otherwise stated, these specifications apply for: TA = 25°C; Pwr VCC = VCC = 12V; ROSC = 20k to VREF; COSC = 2nF; RTACH = 33k; CTACH = 10nF; and all outputs unloaded. TA = TJ.

PARAMETER	TEST CONDITIONS	MIN	TYP	MAX	UNITS
SSTART Restart Threshold		0.1	0.2	0.3	V
Current Amp					
Gain	ISENSE1 = .3V, ISENSE2 = .5V to .7V	1.75	1.95	2.15	V/V
Current Amp (cont.)					
Level Shift	ISENSE1 = .3V, ISENSE2 = .3V	2.4	2.5	2.65	V
Peak Current Threshold	ISENSE1 = 0V, Force ISENSE2	0.14	0.20	0.26	V
Over Current Threshold	ISENSE1 = 0V, Force ISENSE2	0.26	0.30	0.36	V
ISENSE1, ISENSE2 Input Current	To 0V	-850	-320	0	μA
ISENSE1, ISENSE2 Offset Current	To 0V		±2	±12	μA
Range ISENSE1, ISENSE2		-1		2	V
Tachometer/Brake					
Tach-Out High Level	Over Operating Range, 10k to 2.5V	4.7	5	5.3	V
Tach-Out Low Level	Over Operating Range, 10k to 2.5V			0.2	V
On Time		170	220	280	μs
On Time Change With Temp	Over Operating Range		0.1		%
RC-Brake Input Current	To 0V	-4.0	-1.9		mA
Threshold to Brake, RC-Brake	Over Operating Range	0.8	1.0	1.2	V
Brake Hysteresis, RC-Brake			0.09		V
Speed-In Threshold	Over Operating Range	220	257	290	mV
Speed-In Input Current		-30	-5	30	μA
Low-Side Drivers					
Voh, -1mA, Down From Vcc	Over Operating Range		1.60	2.1	
V Voh, -50mA, Down From Vcc	Over Operating Range		1.75	2.2	V
Vol, 1mA	Over Operating Range		0.05	0.4	V
Vol, 50mA	Over Operating Range		0.36	0.8	V
Rise/Fall Time	10% to 90% Slew Time, into 1nF		50		ns
High-Side Drivers					
Vol, 1mA	Over Operating Range		0.1	0.4	V
Vol, 50mA	Over Operating Range		1.0	1.8	V
Leakage Current	Output Voltage = 50V			25	μA
Fall Time	10% to 90% Slew Time, 50mA Load		50		ns
Oscillator					
Frequency		40	50	60	kHz
Frequency	Over Operating Range	35		65	kHz
Reference					
Output Voltage		4.9	5.0	5.1	V
Output Voltage	Over Operating Range	4.7	5.0	5.3	V
Load Regulation	0mA to -20mA Load	-40	-5		mV
Line Regulation	10V to 18V Vcc	-10	-1	10	mV
Short Circuit Current	Over Operating Range	50	100	150	mA
Miscellaneous					
Output Turn-On Delay			1		μs
Output Turn-Off Delay			1		μs

PIN DESCRIPTIONS

Dir, Speed-In: The position decoder logic translates the Hall signals and the Dir signal to the correct driver signals (PUs and PDs). To prevent output stage damage, the signal on Dir is first loaded into a direction latch, then shifted through a two-bit register.

As long as Speed-In is less than 250mV, the direction latch is transparent. When Speed-In is higher than 250mV, the direction latch inhibits all changes in direction. Speed-In can be connected to Tach-Out through a filter, so that the direction latch is only transparent when the motor is spinning slowly, and has too little stored energy to damage power devices.

Additional circuitry detects when the input and output of the direction latch are different, or when the input and output of the shift register are different, and inhibits all output drives during that time. This can be used to allow the motor to coast to a safe speed before reversing.

The shift register guarantees that direction can't be changed instantaneously. The register is clocked by the PWM oscillator, so the delay between direction changes is always going to be between one and two oscillator periods. At 40kHz, this corresponds to a delay of between 25µs and 50µs. Regardless of output stage, 25µs dead time should be adequate to guarantee no overlap cross-conduction. Toggling DIR will cause an output pulse on Tach-Out regardless of motor speed.

E/A In(+), E/A In(-), E/A Out, PWM In: E/A In(+) and E/A In(-) are not internally committed to allow for a wide variety of uses. They can be connected to the ISENSE, to Tach-Out through a filter, to an external command voltage, to a D/A converter for computer control, or to another op amp for more elegant feedback loops. The error amplifier is compensated for unity gain stability, so E/A Out can be tied to E/A In(-) for feedback and major loop compensation.

E/A Out and PWM In drive the PWM comparator. For voltage-mode PWM systems, PWM In can be connected to RC-Osc. The PWM comparator clears the PWM latch, commanding the outputs to chop.

The error amplifier can be biased off by connecting E/A In(-) to a higher voltage than E/A In(+). When biased off, E/A Out will appear to the application as a resistor to ground. E/A Out can then be driven by an external amplifier.

GND: All thresholds and outputs are referred to the GND pin except for the PD and PU outputs.

H1, H2, H3: The three shaft-position sensor inputs consist of hysteresis comparators with input pull-up resistors. Logic thresholds meet TTL specifications and can be driven by 5V CMOS, 12V CMOS, NMOS, or open-collectors.

Connect these inputs to motor shaft position sensors that are positioned 120 electrical degrees apart. If noisy signals are expected, zener clamp and filter these inputs with 6V zeners and an RC filter. Suggested filtering components are 1k and 2nF. Edge skew in the filter is not a problem, because sensors normally generate modified Gray code with only one output changing at a time, but rise and fall times must be shorter than 20µs for correct tachometer operation.

Motors with 60 electrical degree position sensor coding can be used if one or two of the position sensor signals is inverted.

ISENSE1, ISENSE2, ISENSE: The current sense amplifier has a fixed gain of approximately two. It also has a built-in level shift of approximately 2.5 volts. The signal appearing on ISENSE is:

$$ISENSE = 2.5V + (2 * ABS (ISENSE1 - ISENSE2))$$

ISENSE1 and ISENSE2 are interchangeable and can be used as differential inputs. The differential signal applied can be as high as ±0.5V before saturation.

If spikes are expected on ISENSE1 or ISENSE2, they are best filtered by a capacitor from ISENSE to ground. Filtering this way allows fast signal inversions to be correctly processed by the absolute value circuit. The peak-current comparator allows the PWM to enter a current-limit mode with current in the windings never exceeding approximately 0.2V/RSENSE. The over current comparator provides a fail-safe shutdown in the unlikely case of current exceeding 0.3V/RSENSE. Then, soft start is commanded, and all outputs are turned off until the high current condition is removed. It is often essential to use some filter driving ISENSE1 and ISENSE2 to reject extreme spikes and to control slew rate. Reasonable starting values for filter components might be 250Ω series resistors and a 5nF capacitor between ISENSE1 and ISENSE2. Input resistors should be kept small and matched to maintain gain accuracy.

OV-Coast: This input can be used as an over-voltage shutdown in put, as a coast input, or both. This input can be driven by TTL, 5V CMOS, or 12V CMOS.

PDA, PDB, PDC: These outputs can drive the gates of N-Channel power MOSFETs directly or they can drive the bases of power Darlington's if some form of current limiting is used. They are meant to drive low-side power devices in high-current output stages. Current available from these pins can peak as high as 0.5A. These outputs feature a true totem-pole output stage. Beware of exceeding IC power dissipation limits when using these outputs for high continuous currents. These outputs pull high to turn a "low-side" device on (active high).

PIN DESCRIPTIONS (cont.):

PUA, PUB, PUC: These outputs are open-collector, high-voltage drivers that are meant to drive high-side power devices in high-current output stages. These are active low outputs, meaning that these outputs pull low to command a high-side device on. These outputs can drive low-voltage PNP Darlington and P-channel MOSFETs directly, and can drive any high-voltage device using external charge-pump techniques, transformer signal coupling, cascode level-shift transistors, or opto-isolated drive. (See applications).

PWR Vcc: This supply pin carries the current sourced by the PD outputs. When connecting PD outputs directly to the bases of power Darlington, the PWR Vcc pin can be current limited with a resistor. Darlington outputs can also be "Baker Clamped" with diodes from collectors back to PWR Vcc. (See Applications)

Quad Sel: The IC can chop power devices in either of two modes, referred to as "two-quadrant" (Quad Sel low) and "four-quadrant" (Quad Sel high). When two-quadrant chopping, the pull-down power devices are chopped by the output of the PWM latch while the pull-up drivers remain on. The load will chop into one commutation diode, and except for back-EMF, will exhibit slow discharge current and faster charge current. Two-quadrant chopping can be more efficient than four-quadrant.

When four-quadrant chopping, all power drivers are chopped by the PWM latch, causing the load current to flow into two diodes during chopping. This mode exhibits better control of load current when current is low, and is preferred in servo systems for equal control over acceleration and deceleration. The Quad Sel input has no effect on operation during braking.

RC-Brake: Each time the Tach-Out pulses, the capacitor tied to RC-Brake discharges from approximately 3.33V down to 1.67V through a resistor. The tachometer pulse width is approximately $T = 0.67 R_T C_T$, where R_T and C_T are a resistor and capacitor from RC-Brake to ground. Recommended values for R_T are 10k to 500k, and recommended values for C_T are 1nF to 100nF, allowing times between 5 μ s and 10ms. Best accuracy and stability are achieved with values in the centers of those ranges.

RC-Brake also has another function. If RC-Brake pin is pulled below the brake threshold, the IC will enter brake mode. This mode consists of turning off all three high-side devices, enabling all three low-side devices, and disabling the tachometer. The only things that inhibit low-side device operation in braking are low-supply, exceeding peak current, OV-Coast command, and the PWM comparator signal. The last of these means that if current sense is implemented such that the signal in the current sense amplifier is proportional to braking current,

the low-side devices will brake the motor with current control. (See applications) Simpler current sense connections will result in uncontrolled braking and potential damage to the power devices.

RC-Osc: The UC3625 can regulate motor current using fixed-frequency pulse width modulation (PWM). The RC-Osc pin sets oscillator frequency by means of timing resistor ROSC from the RC-Osc pin to VREF and capacitor COSC from RC-Osc to Gnd. Resistors 10k to 100k and capacitors 1nF to 100nF will work best, but frequency should always be below 500kHz. Oscillator frequency is approximately:

$$F = 2 / R_{osc} C_{osc}$$

Additional components can be added to this device to cause it to operate as a fixed off-time PWM rather than a fixed frequency PWM, using the RC-Osc pin to select the monostable time constant.

The voltage on the RC-Osc pin is normally a ramp of about 1.2V peak-to-peak, centered at approximately 1.6V. This ramp can be used for voltage-mode PWM control, or can be used for slope compensation in current-mode control.

SSTART: Any time that Vcc drops below threshold or the sensed current exceeds the over-current threshold, the soft-start latch is set. When set, it turns on a transistor that pulls down on SSTART. Normally, a capacitor is connected to this pin, and the transistor will completely discharge the capacitor. A comparator senses when the NPN transistor has completely discharged the capacitor, and allows the soft-start latch to clear when the fault is removed. When the fault is removed, the soft-start capacitor will charge from the on-chip current source.

SSTART clamps the output of the error amplifier, not allowing the error amplifier output voltage to exceed SSTART regardless of input. The ramp on RC-Osc can be applied to PWM In and compared to E/A Out. With SSTART discharged below 0.2V and the ramp minimum being approximately 1.0V, the PWM comparator will keep the PWM latch cleared and the outputs off. As SSTART rises, the PWM comparator will begin to duty-cycle modulate the PWM latch until the error amplifier inputs overcome the clamp. This provides for a safe and orderly motor start-up from an off or fault condition.

Tach-Out: Any change in the H1, H2, or H3 inputs loads data from these inputs into the position sensor latches. At the same time data is loaded, a fixed-width 5V pulse is triggered on Tach-Out. The average value of the voltage on Tach-Out is directly proportional to speed, so this output can be used as a true tachometer for speed feedback with an external filter or averaging circuit.

PIN DESCRIPTIONS (cont.):

Whenever Tach-Out is high, the position latches are inhibited, such that during the noisiest part of the commutation cycle, additional commutations are not possible. Although this will effectively set a maximum rotational speed, the maximum speed can be set above the highest expected speed, preventing false commutation and chatter.

Vcc: This device operates with supplies between 10V and 18V. Under-voltage lockout keeps all outputs off below 7.5V, insuring that the output transistors never turn on until full drive capability is available. Bypass VCC to

ground with an 0.1 μ F ceramic capacitor. Using a 10 μ F electrolytic bypass capacitor as well can be beneficial in applications with high supply impedance.

VREF: This pin provides regulated 5 volts for driving Hall-effect devices and speed control circuitry. VREF will reach +5V before VCC enables, ensuring that Hall-effect devices powered from VREF will become active before the UC3625 drives any output. Although VREF is current limited, operation over 30mA is not advised. For proper performance VREF should be bypassed with at least a 0.1 μ F capacitor to ground.

CROSS CONDUCTION PREVENTION

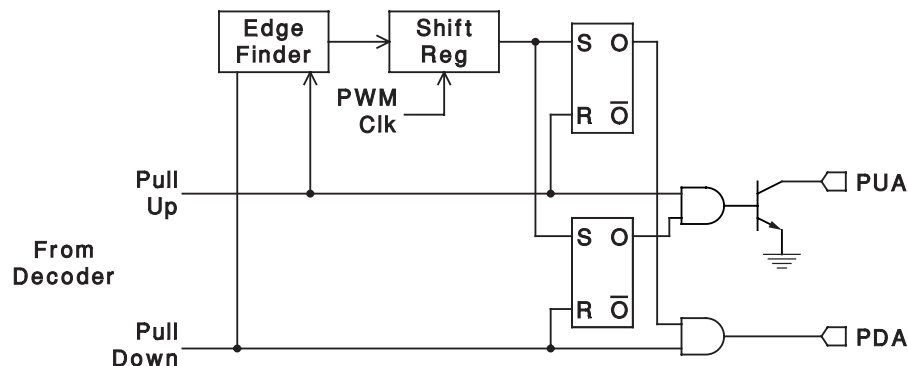

The UC3625 inserts delays to prevent cross conduction due to overlapping drive signals. However, some thought must always be given to cross conduction in output stage design because no amount of dead time can prevent fast slewing signals from coupling drive to a power device through a parasitic capacitance.

The UC3625 contains input latches that serve as noise blanking filters. These latches remain transparent through any phase of a motor rotation and latch immediately after an input transition is detected. They remain latched for two cycles of the PWM oscillator. At a PWM oscillator speed of 20kHz, this corresponds to 50 μ s to 100 μ s of blank time which limits maximum rotational speed to 100kRPM for a motor with six transitions per rotation or 50kRPM for a motor with 12 transitions per rotation.

This prevents noise generated in the first 50 μ s of a transition from propagating to the output transistors and causing cross-conduction or chatter.

The UC3625 also contains six flip flops corresponding to the six output drive signals. One of these flip flops is set every time that an output drive signal is turned on, and cleared two PWM oscillator cycles after that drive signal is turned off. The output of each flip flop is used to inhibit drive to the opposing output. (see below) In this way, it is impossible to turn on driver PUA and PDA at the same time. It is also impossible for one of these drivers to turn on without the other driver having been off for at least two PWM oscillator clocks.

TYPICAL CHARACTERISTICS:

Oscillator Frequency vs C_{osc} and R_{osc}

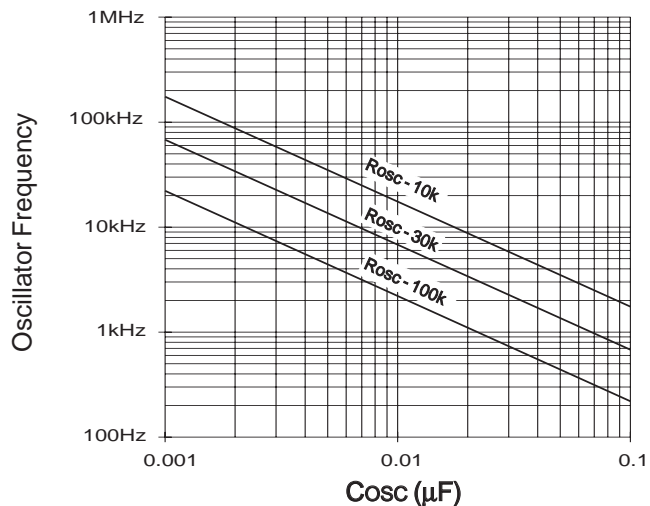

Tachometer On Time vs R_T and C_T

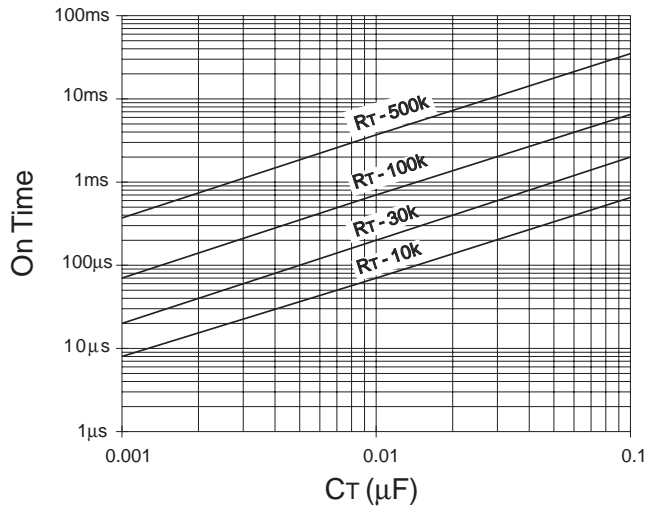

Supply Current vs Temperature

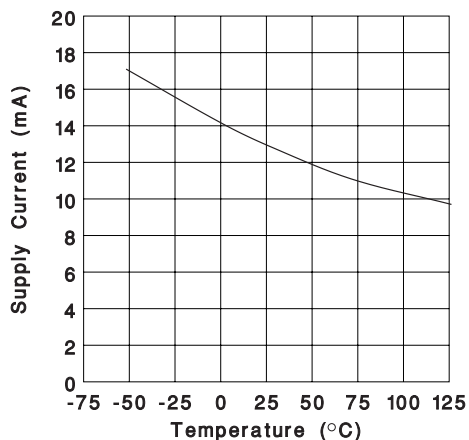

Soft Start Pull-Up Current vs Temperature

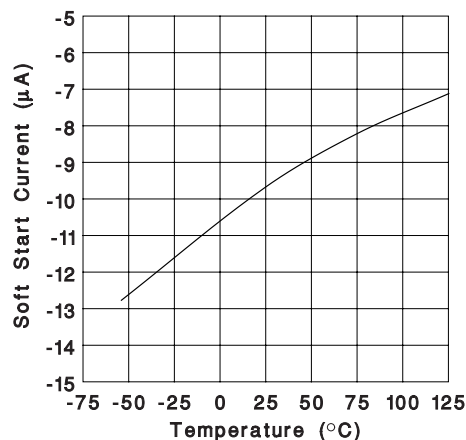

Soft Start Discharge Current vs Temperature

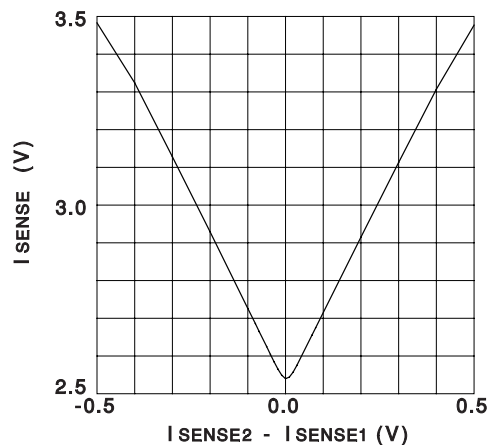
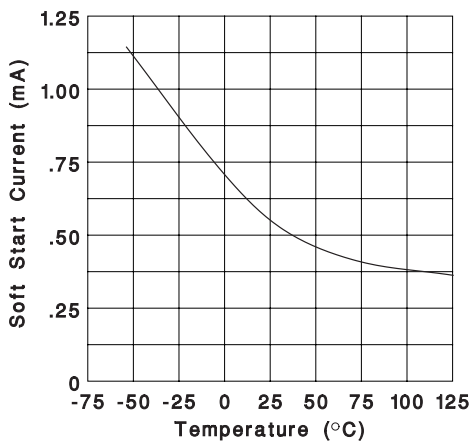

POWER STAGE DESIGN:

The UC3625 is useful in a wide variety of applications, including high-power in robotics and machinery. The power output stages used in such equipment can take a number of forms, according to the intended performance and purpose of the system. Below are four different power stages with the advantages and disadvantages of each shown.

For high-frequency chopping, fast recovery circulating diodes are essential. Six are required to clamp the windings. These diodes should have a continuous current rating at least equal to the operating motor current, since diode conduction duty-cycle can be high. For low-voltage systems, Schottky diodes are preferred. In higher voltage systems, diodes such as Microsemi UHVP high voltage platinum rectifiers are recommended.

In a pulse-by-pulse current control arrangement, current sensing is done by resistor R_T , through which the transistor's currents are passed (Figures A, B, and C). In these cases, R_D is not needed. The low-side circulating

diodes go to ground and the current sense terminals of the UC3625 (I_{SENSE1} and I_{SENSE2}) are connected to R_T through an R_c filter. The input bias current of the current sense amplifier will cause a common mode offset voltage to appear at both inputs, so for best accuracy, keep the filter resistors below 2k and matched.

The current that flows through R_T is discontinuous because of chopping. It flows during the on time of the power stage and is zero during the off time. Consequently, the voltage across R_T consists of a series of pulses, occurring at the PWM frequency, with a peak value indicative of the peak motor current.

To sense average motor current instead of peak current, add another current sense resistor (R_D in Figure D) to measure current in the low-side circulating diodes, and operate in four quadrant mode (pin 22 high). The negative voltage across R_D is corrected by the absolute value current sense amplifier. Within the limitations imposed by Table 1, the circuit of Figure B can also sense average current.

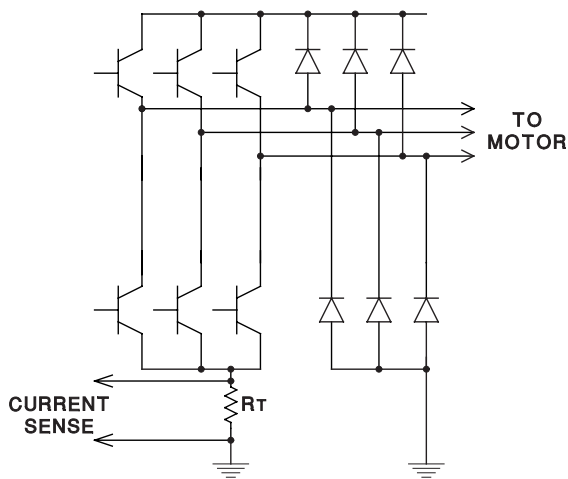

FIGURE A

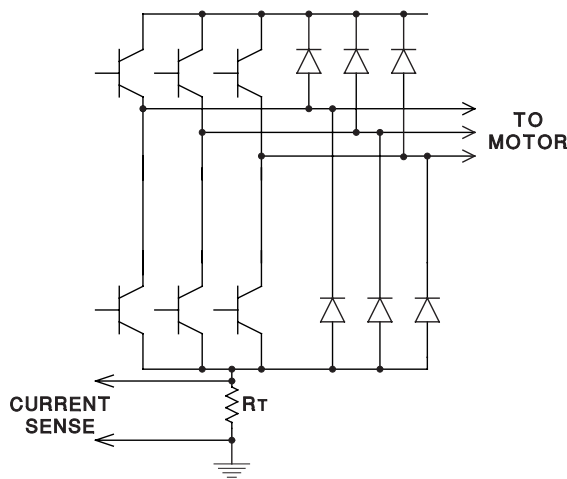

FIGURE B

POWER STAGE DESIGN (cont.):

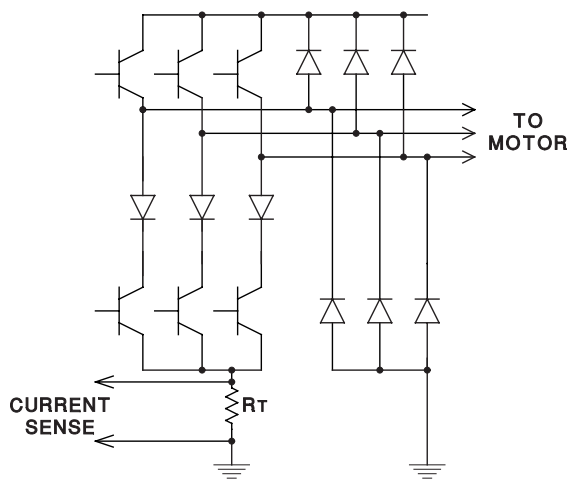

FIGURE C

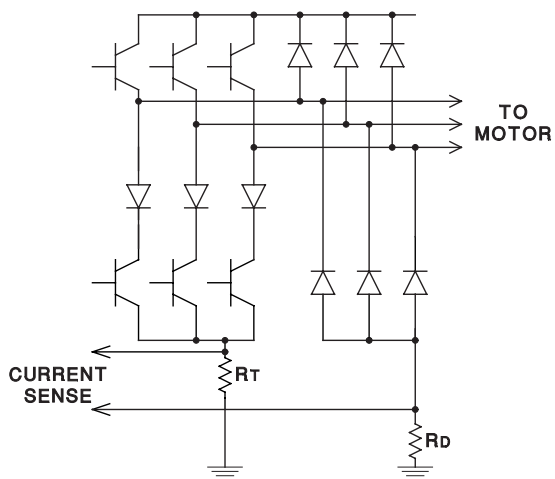
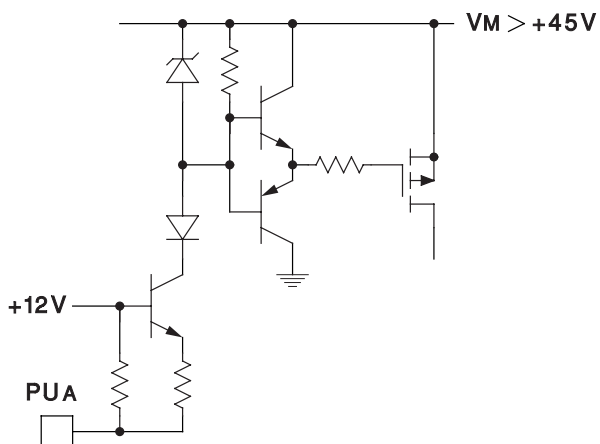

FIGURE D

	2 QUADRANT	4 QUADRANT	SAFE BRAKING	POWER REVERSE	CURRENT SENSE	
					PULSE BY PULSE	AVERAGE
FIGURE A	YES	NO	NO	NO	YES	NO
FIGURE B	YES	YES	NO	IN 4QUAD MODE ONLY	YES	YES
FIGURE C	YES	YES	YES	IN 4QUAD MODE ONLY	YES	NO
FIGURE D	YES	YES	YES	IN 4QUAD MODE ONLY	YES	YES

Fast High-Side P-Channel Driver



Optocoupled N-Channel High-Side Driver

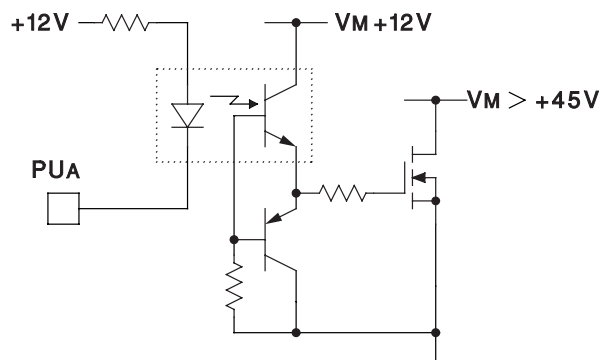

For drives where speed is critical, P-Channel MOSFETs can be driven by emitter followers. Here, both the level shift NPN and the PNP must withstand high voltages. A zener diode is used to limit gate-source voltage on the MOSFET. A series gate resistor is not necessary, but always advisable to control overshoot and ringing.

High-voltage optocouplers can quickly drive high-voltage MOSFETs if a boost supply of at least 10 volts greater than the motor supply is provided. To protect the MOSFET, the boost supply should not be higher than 18 volts above the motor supply.

Power NPN High-Side Driver

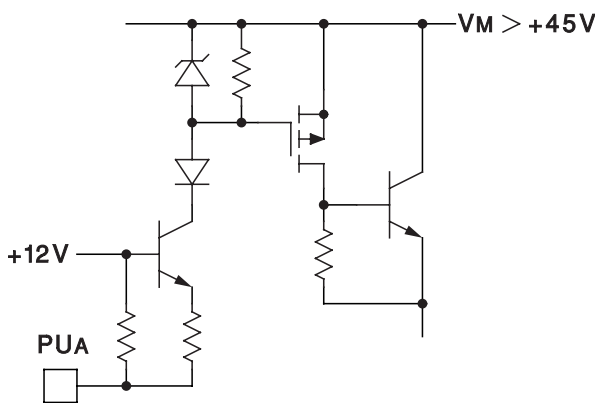

Power NPN Low-Side Driver

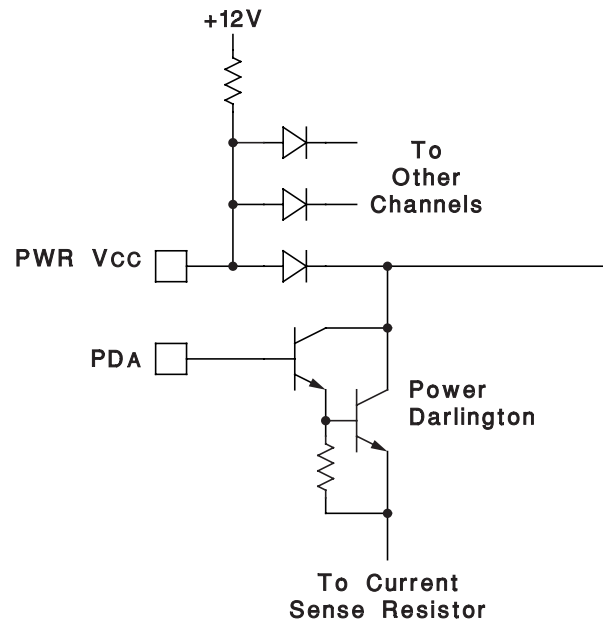

For under 200V 2-quadrant applications, a power NPN driven by a small P-Channel MOSFET will perform well as a high-side driver. A high voltage small-signal NPN is used as a level shift and a high voltage low-current MOSFET provides drive. Although the NPN will not saturate if used within its limitations, the base-emitter resistor on the NPN is still the speed limiting component.

This power NPN Darlington drive technique uses a clamp to prevent deep saturation. By limiting saturation of the power device, excessive base drive is minimized and turn-off time is kept fairly short. Lack of base series resistance also adds to the speed of this approach.

Fast High-Side N-Channel Driver with Transformer Isolation

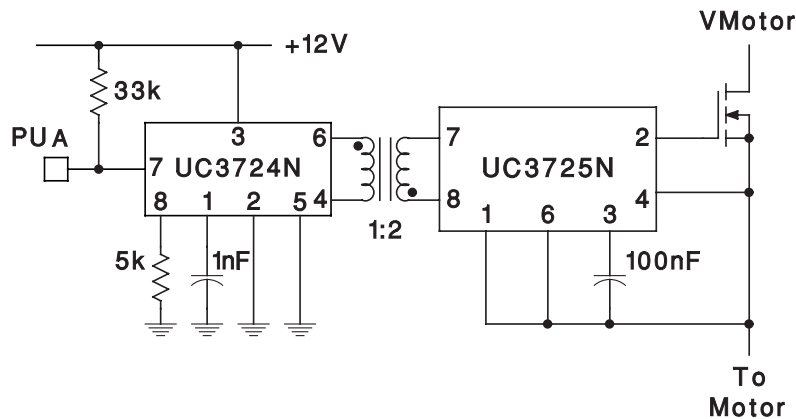

A small pulse transformer can provide excellent isolation between the UC3625 and a high-voltage N-Channel MOSFET while also coupling gate drive power. In this circuit, a UC3724 is used as a transformer driver/encoder that duty-cycle modulates the transformer with a 150kHz pulse train. The UC3725 rectifies this pulse train for gate drive power, demodulates the signal, and drives the gate with over 2 amp peak current.

Both the UC3724 and the UC3725 can operate up to 500kHz if the pulse transformer is selected appropriately. To raise the operating frequency, either lower the

timing resistor of the UC3724 (1k minimum), lower the timing capacitor of the UC3724 (500pF minimum) or both.

If there is significant capacitance between transformer primary and secondary, together with very high output slew rate, then it may be necessary to add clamp diodes from the transformer primary to +12V and ground. Signal diodes such as 1N4148 are normally adequate.

The UC3725 also has provisions for MOSFET current limiting. Consult the UC3725 data sheet for more information on implementing this.

COMMUTATION TRUTH TABLE

This table shows the outputs of the gate drive and open collector outputs for given hall input codes and direction signals. Numbers at the top of the columns are pin numbers.

These ICs operate with position sensor encoding that has either one or two signals high at a time, never all low or all high. This coding is sometimes referred to as "120° Coding" because the coding is the same as coding with position sensors spaced 120 magnetic degrees about the rotor. In response to these position sense signals, only one low-side driver will turn on (go high) and one high-side driver will turn on (pull low) at any time.

DIR	INPUTS			OUTPUTS					
	H1	H2	H3	Low-Side			High-Side		
6	8	9	10	12	13	14	16	17	18
1	0	0	1	L	H	L	L	H	H
1	0	1	1	L	L	H	L	H	H
1	0	1	0	L	L	H	H	L	H
1	1	1	0	H	L	L	H	L	H
1	1	0	0	H	L	L	H	H	L
1	1	0	1	L	H	L	H	H	L
0	1	0	1	L	L	H	H	L	H
0	1	0	0	L	L	H	L	H	H
0	1	1	0	L	H	L	L	H	H
0	0	1	0	L	H	L	H	H	L
0	0	1	1	H	L	L	H	H	L
0	0	0	1	H	L	L	H	L	H
X	1	1	1	L	L	L	H	H	H
X	0	0	0	L	L	L	H	H	H

TYPICAL APPLICATION: A 45V/8A Brushless DC Motor Drive Circuit

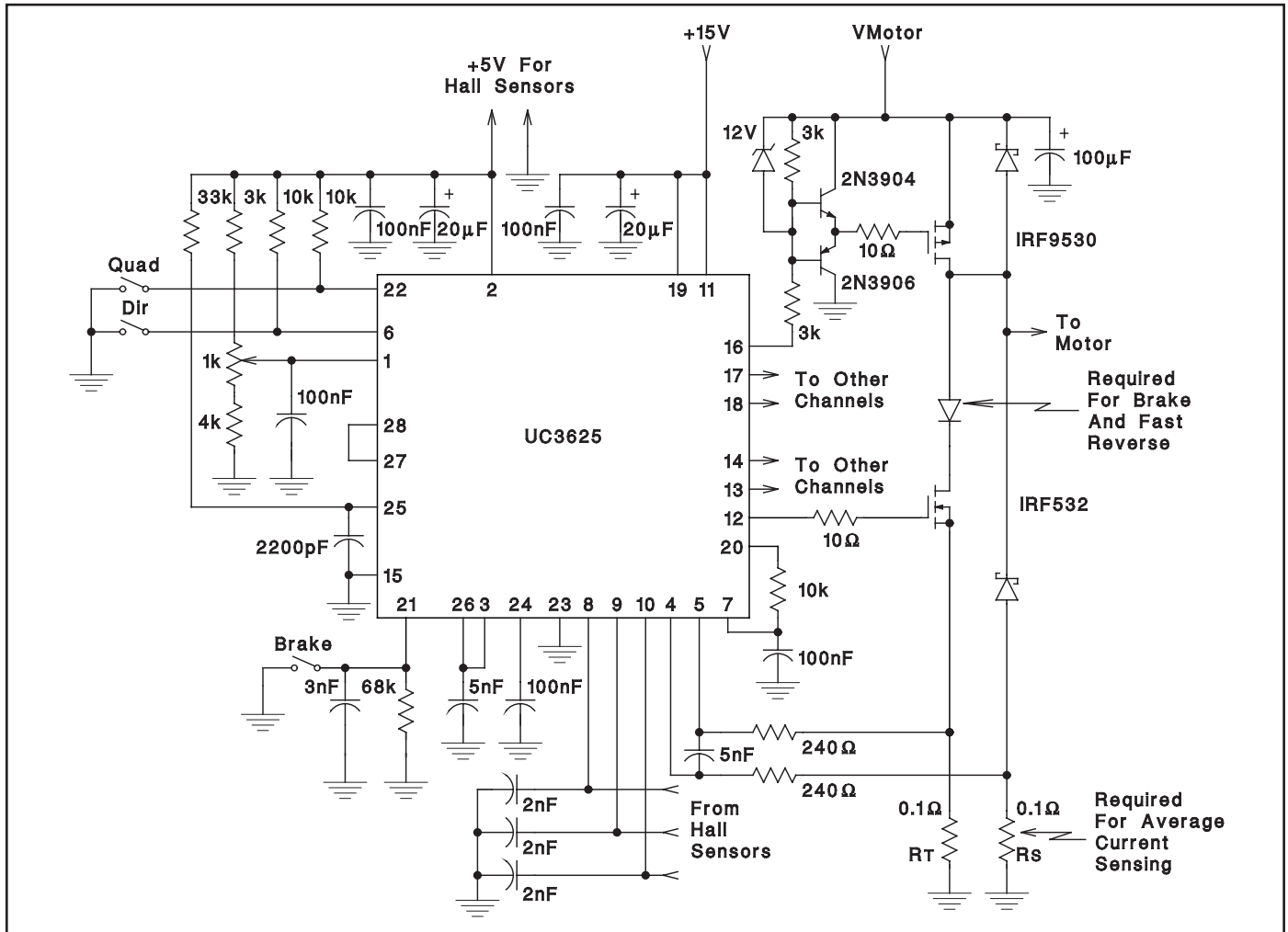

N-Channel power MOSFETs are used for low-side drivers, while P-Channel power MOSFETs are shown for high-side drivers. Resistors are used to level shift the UC3625 open-collector outputs, driving emitter followers into the MOSFET gate. A 12V zener clamp insures that the MOSFET gate-source voltage will never exceed 12V. Series 10Ω gate resistors tame gate reactance, preventing oscillations and minimizing ringing.

The oscillator timing capacitor should be placed close to pins 15 and 25, to keep ground current out of the capacitor. Ground current in the timing capacitor causes oscillator distortion and slaving to the commutation signal.

The potentiometer connected to pin 1 controls PWM duty cycle directly, implementing a crude form of speed control. This control is often referred to as "voltage mode" because the potentiometer position sets the average motor voltage. This controls speed because

steady-state motor speed is closely related to applied voltage.

Pin 20 (Tach-Out) is connected to pin 7 (SPEED IN) through an RC filter, preventing direction reversal while the motor is spinning quickly. In two-quadrant operation, this reversal can cause kinetic energy from the motor to be forced into the power MOSFETs.

A diode in series with the low-side MOSFETs facilitates PWM current control during braking by insuring that braking current will not flow backwards through low-side MOSFETs. Dual current-sense resistors give continuous current sense, whether braking or running in four-quadrant operation, an unnecessary luxury for two-quadrant operation.

The 68k ohm and 3nF tachometer components set maximum commutation time at 140μs. This permits smooth operation up to 35,000 RPM for four-pole motors, yet gives 140μs of noise blanking after commutation.